

OWNER'S MANUAL

CLASSIC 600

VHR

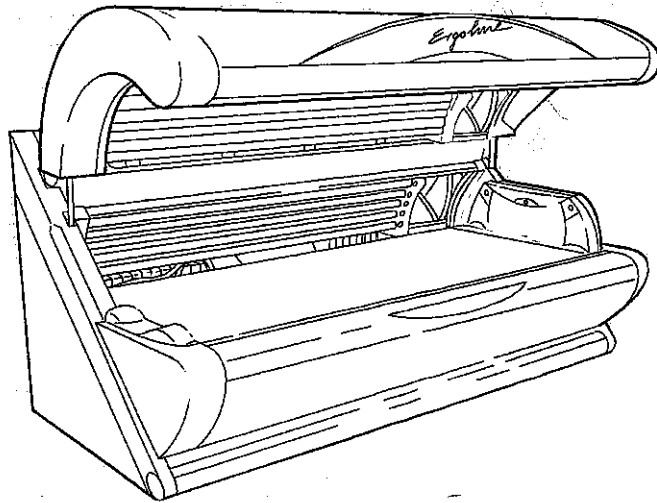

Ergoline

Specifications

600

Length: 92"

Width: 51"

Height: 52"

Shipping Weight: 1500 Lbs.

No. of Lamps: 59 (50-160 Watt, 4-500 Watt, 5-25 Watt)

Electrical: 32 AMPS @ 240 Volts 3Ø

Circuit Required: 120/240V 3 Ø
50 Amp 3-Pole

DANGER - ULTRAVIOLET RADIATION. FOLLOW INSTRUCTIONS. AVOID OVEREXPOSURE. AS WITH NATURAL SUNLIGHT, OVEREXPOSURE CAN CAUSE EYE AND SKIN INJURY AND ALLERGIC REACTIONS. REPEATED EXPOSURE MAY CAUSE PREMATURE AGING OF THE SKIN AND SKIN CANCER. WEAR PROTECTIVE EYEWEAR; FAILURE TO MAY RESULT IN SEVERE BURNS OR LONG-TERM INJURY TO EYES.

MEDICATIONS OR COSMETICS MAY INCREASE YOUR SENSITIVITY TO THE ULTRAVIOLET RADIATION. CONSULT PHYSICIAN BEFORE USING SUNLAMP IF YOU ARE USING MEDICATIONS OR HAVE A HISTORY OF SKIN PROBLEMS OR BELIEVE YOURSELF ESPECIALLY SENSITIVE TO SUNLIGHT. IF YOU DO NOT TAN IN THE SUN, YOU ARE UNLIKELY TO TAN FROM THE USE OF THIS PRODUCT.

THIS UNIT UTILIZES UVA LAMPS. REPLACE ONLY WITH COSMOLUX VHR160W NA1-15-160W, JK ERGOLINE 500 SE C11292 (FACE TANNER) AND ERGOLINE SD POWER 25 11122 (SHOULDER TANNER).



RECOMMENDED EXPOSURE SCHEDULE					
SKIN TYPE	WEEK 1 1 ST-3RD TREATMENTS	WEEK 2 4TH-6TH TREATMENTS	WEEK 3 7TH-10TH TREATMENTS	WEEK 4 11TH-15TH TREATMENTS	WEEKLY SUBSEQUENT TREATMENTS
II - FAIR	3 MIN.	7 MIN.	10 MIN.	12 MIN.	15 MIN.
III - AVERAGE	3 MIN.	7 MIN.	10 MIN.	12 MIN.	15 MIN.
IV - BROWN	3 MIN.	8 MIN.	12 MIN.	15 MIN.	15 MIN.
V - DARK BROWN	3 MIN.	8 MIN.	12 MIN.	15 MIN.	15 MIN.

MAXIMUM EXPOSURE TIME IS 15 MINUTES.

TANNING CAN BEGIN ON A REGULAR BASIS. AN APPEARANCE OF TANNING NORMALLY APPEARS AFTER A FEW EXPOSURES AND MAXIMIZES AFTER FOUR (4) WEEKS OF EXPOSURE FOLLOWING THE RECOMMENDED SCHEDULE FOR YOUR SKIN TYPE.

USE PROTECTIVE EYEWEAR, SUPER SUNNIES, WHENEVER THE EQUIPMENT IS ENERGIZED. READ THE INSTRUCTION BOOKLET BEFORE USING THIS UNIT.

INSTRUCTIONS ACCOMPANYING THIS PRODUCT SHOULD ALWAYS BE FOLLOWED TO AVOID OR MINIMIZE POTENTIAL INJURY.

"THIS PRODUCT IS IN CONFORMITY WITH PERFORMANCE STANDARDS FOR SUNLAMP PRODUCTS UNDER 21CFR PART 1040."

General Safety Information

Safety Recommendations

1. The Sun Ergoline tanning unit must have been assembled and installed properly by trained and experienced personnel.
2. Compliance with all the warning and safety labels attached to the tanning unit required.
3. No safety device or safety notice may be removed or disabled, as doing so could impair the reliable functioning of the tanning unit.
4. The tanning unit must only be operated under the guidelines in this manual.
5. The tanning unit must only be operated when in full working order.
6. Carefully read all instruction included in this Sun Ergoline Operation and Instruction Manual.
7. Do not use tanning unit if the timer is inoperative or defective or if the VIT filter glass is cracked, broken or not in place in your unit.
8. Special care should be exercised if the user is particularly sensitive to UV light and if certain medications or cosmetics have been used. If there is any doubt by the salon operator or tanning bed customer, the user should consult with a physician.
9. Cosmetics should be removed prior to each tanning session.
10. Use only lotions, creams and oils specifically designed and formulated for indoor use.
11. Wear protective eyewear anytime the tanning unit is energized.
12. Do not tan more than once per 24 hour period.
13. Follow the recommendations on tanning times, intervals between tanning sessions and the distance from the lamps. Refer to the "Exposure Times and Frequencies" section of this manual for specific details.
14. The tanning unit may not be used by individuals who, when exposed to the sun, develop a sunburn without subsequently tanning.
15. Over exposure to ultraviolet light from the sun or from the tanning unit may cause damage to the skin or eyes. These biological effects will vary due to the individuals specific skin type.
16. Excessive exposure from the tanning unit can lead to sunburn, premature aging and a risk of skin injury.
17. The tanning unit should be utilized by only one person at a time.
18. While there is no immediate clinical evidence of the effects of UVA exposure to expectant mothers, it is strongly advised that expectant mothers be discouraged from using the tanning unit.
19. Persons using the tanning unit could experience a reddening of the skin or heat rash. This rash is often caused by the heat of the tanning system and should go away within 24 hours and should not reappear.

Safety Precautions

1. The installation, electrical connection and the repair of the tanning unit must be performed by a factory trained or approved technician or appropriately qualified personnel.
2. The electrical installation must comply with all national and local electrical codes.
3. The tanning unit must be operated as specified in this instruction manual.
4. The tanning unit may only be operated under the timer control for a maximum of 15 minutes. The display on the timer should be set to the recommended time for your specific skin type based on the number of exposures. Increasing the timer settings or disabling the timer could result in injury.

Care and Cleaning of Your Tanning Unit

After each session is completed, spray the acrylic surface with specially formulated UVT (ultraviolet transmitting) acrylic cleaner. Wipe the surface of the acrylic with a clean cloth. The acrylic should

never be wiped with a dry cloth because this will generate a slight static charge which will attract dust. A mild liquid detergent and water solution can be used temporarily in place of Acrylic Cleaner.

For maximum efficiency of your tanning unit, periodic cleaning of lamps, reflectors and the inside of the acrylics is required. Refer to relamping instructions for acrylic removal.

CAUTION: Do not use excessive amounts of water, any abrasive cleaners, or any spray cleaners that carry label warnings regarding reactions to contact with skin!

DO NOT USE ALCOHOL OR AMMONIA

Electrical Safety:

The tanning unit should be disconnected from the power supply before cleaning or disinfecting the inside of the acrylic. Avoid water or solution entering the lamp compartment.

Relamping Instructions

Base Lamp Removal

1. Unlock bottom unit acrylic with the provided Ergoline Service Key. Insert key in lock at head end of bottom unit and turn clockwise 1/4 turn. (Refer to Illustration L1)

2. Raise the acrylic panel assembly until locked. The panel should lock in an upright position to allow access to inner acrylic.

3. Remove the lower acrylic panel by placing index finger under the provided slot and lifting edge of acrylic. Lift acrylic from the end of sheet allowing the rear edge to slide from slot behind the lamps. (Refer to Illustration L2)

4. Remove both head and foot starter covers as shown. (Refer to Illustration L3)

5. To remove lamps turn lamp 1/4 turn and slide lamp from lampholder.

6. To install lamps place lamp in lampholder and turn lamp 1/4 turn. To install lamp properly the lamp etch must be facing the acrylic.

7. Repeat Steps 1 through 4 in reverse order to reassemble the tanning unit.

Illustration L1

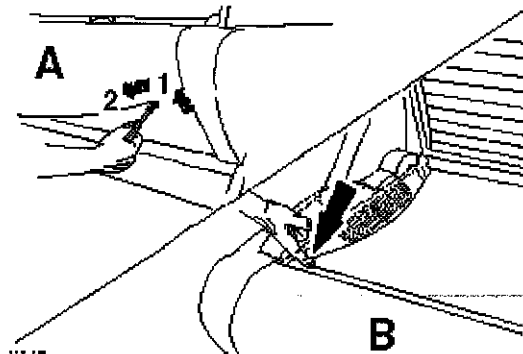
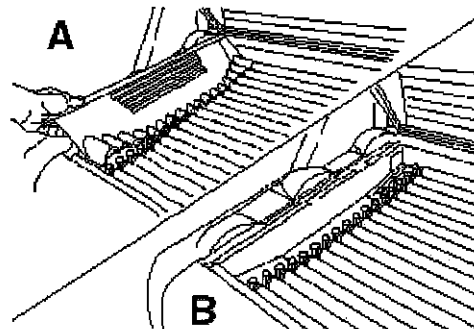

Illustration L2

Illustration L3



Relamping Instructions

Side Panel Lamp Removal

1. Detach side panel acrylic from profile retaining frame by removing acrylic attaching screws with the provided Ergoline Service Key. (Refer to Illustration L4)
2. The acrylic side panel will hinge down.
3. Remove attaching screw from the starter cover with the Ergoline Service Key and hinge down.
4. To remove lamps turn 1/4 turn and slide lamp from lampholder.
5. To install lamps place lamp in lampholder and turn lamp 1/4 turn. To install lamp properly the lamp etch must be facing the acrylic.
6. Repeat Steps 1 through 4 in reverse order to reassemble the tanning unit.

Illustration L4

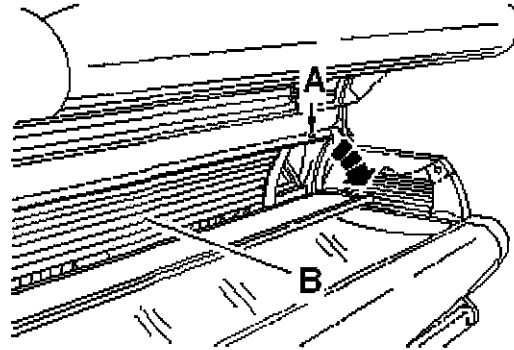
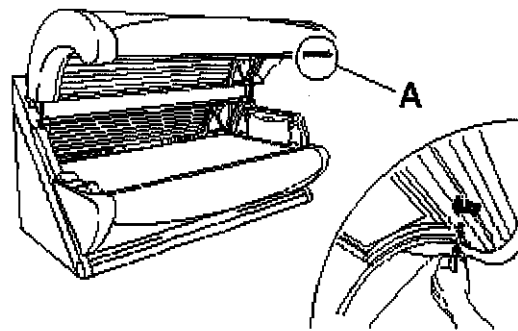

Illustration L5



Top Canopy Lamp Removal

1. To detach top unit acrylic apply pressure to the acrylic assembly and rotate the acrylic latches clockwise. The acrylic assembly is attached with two retainers, one at the head and one at the foot end of the canopy. (Refer to Illustration L5)
2. After detaching the acrylic assembly, carefully lower the front down, resting the assembly on the base of the unit. (Refer to Illustration L6)
3. To remove lamps turn lamp 1/4 turn and slide lamp from lampholder.
4. To install lamps place lamp in lamp holder and turn lamp 1/4 turn. To install lamp properly the lamp etch must be facing the acrylic.
5. To install the top unit acrylic assembly lift assembly into position and apply force. Turn the two acrylic latches counter clockwise until latched.

Illustration L6

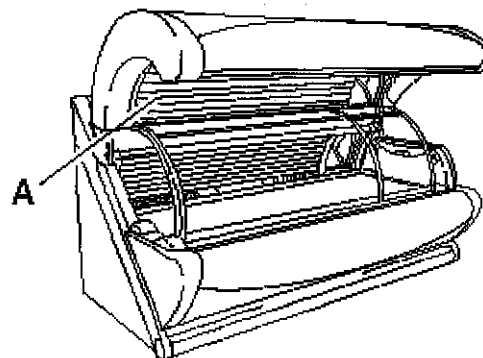

Note:

If lamps will not light inspect the lamp. The Sun Ergoline 600 utilizes reflector lamps and only emits UV light from the top side of the lamp. It is also recommended during a lamp change that you inspect all starters to insure they are in good working order and replace if necessary.

Relamping Instructions

Side Panel Facial Replacement

1. Detach side panel acrylic from profile retaining frame by removing acrylic attaching screws with the provided Ergoline Service Key. **(Refer to Illustration L7)**

2. The acrylic side panel will hinge down.

3. Remove attaching screw from the starter cover with the Ergoline Service Key and hinge down.

4. Remove filter retainer concealment panel by removing the two philips screws. **(Refer to Illustration L8)**

5. Using a large screwdriver or coin turn filter retaining twist locks 1/4 turn and remove filter lens. **(Refer to Illustration L8)**

6. Remove facial lamp using a pair of offset needle nose pliers. Carefully place the pliers on the ceramic lamp base and apply outward pressure. **(Refer to Illustration L9)**

7. Clean the VIT reflector with a damp cloth.

8. Prior to handling the new facial lamp it is important to not touch the glass envelope of the lamp with your hands. The oil from your fingers will cause the lamp to malfunction and rupture.

9. To install the facial lamp, using the offset pliers, grip the lamp by the ceramic base and insert in the lamp socket. You should note that the lamp socket has two different diameters of pin contacts and may only be installed in one direction.

10. Prior to installing the VIT filter panel inspect the operation of the safety switch. Depress the safety switch and release. The switch should spring back to its full extension after it is released. **(Refer to Illustration L9)**

11. Clean VIT filter panel with a damp cloth. Insert filter panel fully into channel at the top of cassette and align in place. Attach filter with the twist locks. The letters VIT 2.3 must be legible from the outside of the cassette. **(Refer to Illustration L8)**

12. Repeat Steps 1 through 4 in reverse order to reassemble unit.

Illustration L7

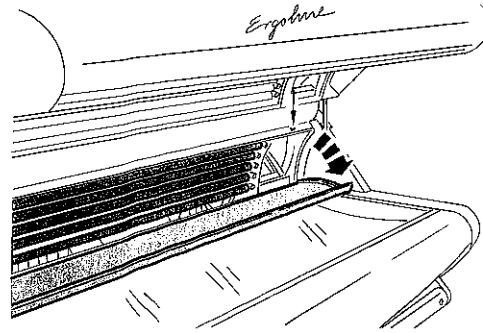

Illustration L8

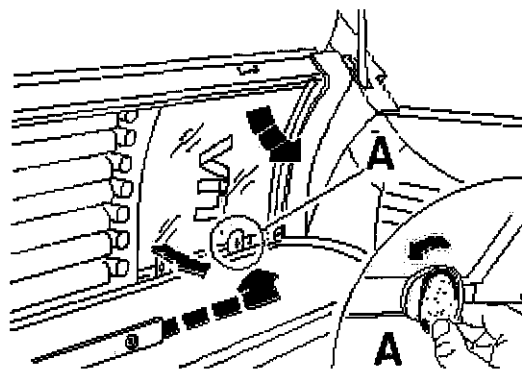
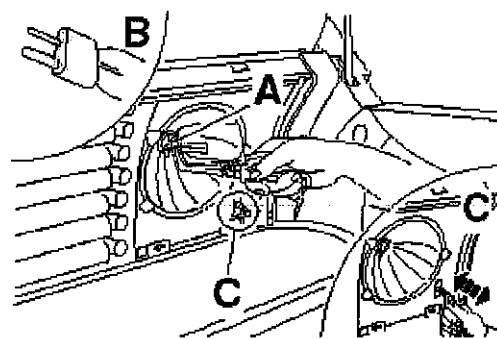

Illustration L9



Relamping Instructions

Canopy Facial Replacement

1. To detach top unit acrylic apply pressure to the acrylic assembly and rotate the acrylic latches clockwise. The acrylic assembly is attached with two retainers, one at the head and one at the foot end of the canopy. **(Refer to Illustration L 10)**

2. After detaching the acrylic assembly carefully lower the front of the assembly down resting the assembly on the base of the unit. **(Refer to Illustration L 11)**

3. Remove twist lock concealment panel by removing the two philips screws. **(Refer to Illustration L 12)**

4. Using a large screwdriver or coin turn filter retaining locks 1/4 turn and remove VIT filter lens. **(Refer to Illustration L 12)**

5. Remove facial lamp using a pair of needle nose offset pliers. Carefully place the pliers on the ceramic lamp base and apply outward pressure. **(Refer to Illustration L 13)**

6. Clean the VIT reflector with a damp cloth.

7. Prior to handling the new facial lamp it is important not to touch the glass envelope of the lamp with you hands. The oil from your finger prints will cause the lamp to malfunction and rupture.

8. To install the facial lamp, using the offset pliers, grip the lamp by the ceramic base and insert in the lamp socket. You should note that the lamp socket has two different diameters of pin contacts and may only be installed in one direction. **(Refer to Illustration L 13)**

9. Prior to installing the VIT filter panel inspect the operation of the safety switch. Depress the safety switch and release. The switch should spring back to its full extension after it is released. **(Refer to Illustration L 13)**

10. Clean VIT filter lens with a damp cloth. Insert filter panel fully into grove at the top of the cassette and align in place. Attach filter with the retainer locks. The letters VIT 2.3 must be legible from the outside of the cassette. **(Refer to Illustration L 12)**

11. Repeat Steps 1 through 3 in reverse order to reassemble unit.

Illustration L10

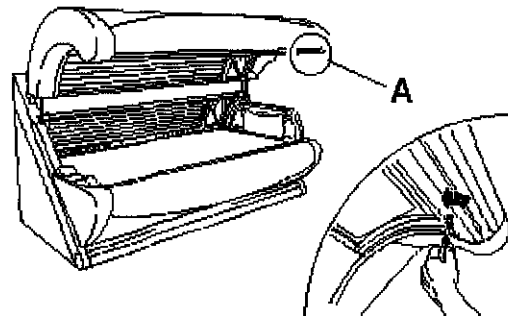

Illustration L 11

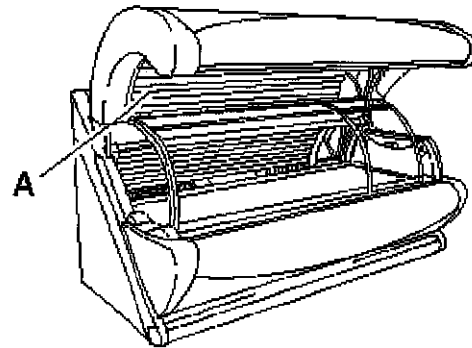

Illustration L12

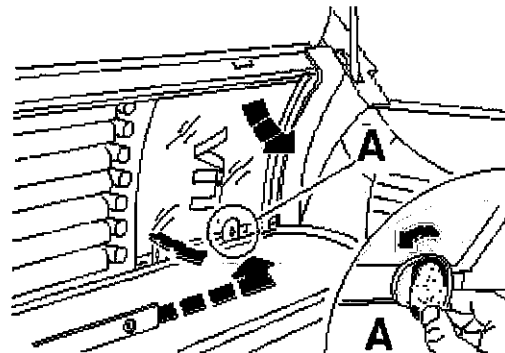
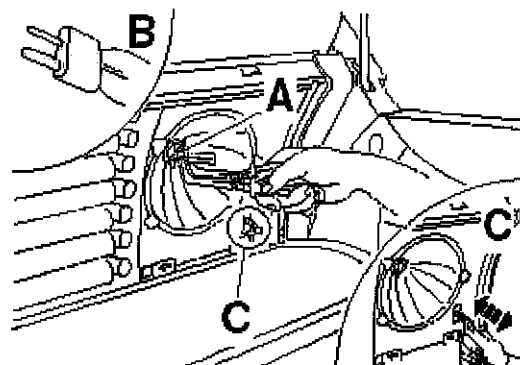

Illustration L13



Relamping Instructions

Shoulder Replacement

12. Remove screw A. Slightly raise cladding panel (B) to disengage it from the lower catch, remove cladding panel towards the front and place it on the acrylic panel.

(Refer to Illustration L14)

13. To remove lamps turn lamp 1/4 turn and slide lamp from lampholder.

14. To install lamps place lamp in lampholder and turn lamp 1/4 turn. To install lamp properly the lamp etch must be facing the acrylic.

15. To install acrylic assembly engage cladding panel (B) into the lower catch and secure the screw (A). **(Refer to Illustration L14)**

Illustration L14

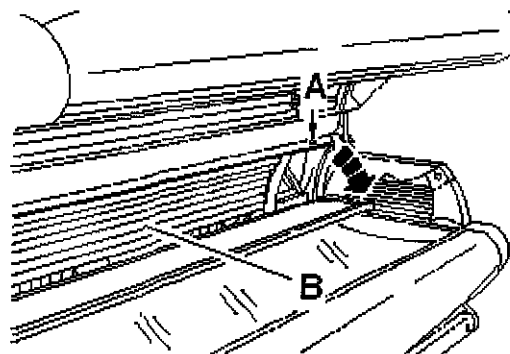

Upper Accent Lighting

16. To detach top unit acrylic apply pressure to the acrylic assembly and rotate the acrylic latches clockwise. The acrylic assembly is attached with two (2) retainers, one at the head and one at the footend of the canopy.

(Refer to Illustration L15)

17. After detaching the acrylic assembly, carefully lower the front down, resting the assembly on the base of the unit.

(Refer to Illustration L16)

18. Remove front five (5) tanning lamps. This will expose inner service panel. Remove inner service panel by removing screw (A) from the inside of the head and footend of the unit.

19. Loosen screws (B) from inner panel. Pull red accent cover from the groove and fold up. Remove screws (B) at this time.

(Refer to Illustration L15)

20. Remove accent lighting turn lamp 1/4 turn and slide lamp from lampholder.

21. To install lamps place lamp in lampholder and turn lamp 1/4 turn.

22. To install red accent cover slide cover into groove and rotate into place. Attach with screws (B). **(Refer to Illustration L15)**

23. Slide inner service panel into place and attach with screws (A).

Illustration L15

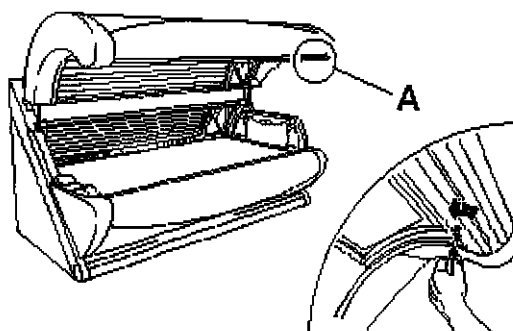
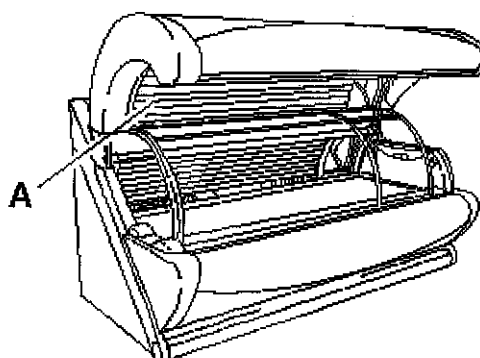

Illustration L16



Relamping Instructions

24. Rotate top acrylic assembly into place and secure by rotating the two (2) acrylic latches counter clockwise.

Lower Accent Lighting

25. Open service compartment with service key. Insert key into lock and turn clockwise 1/4 turn and raise complete base assembly to its full upright position. (Refer to Illustration L16)

26. Lower accent lighting is located along the lower front rail. To remove lamp (A) turn 1/4 turn and slide lamp from lampholder to disengage. (Refer to Illustration L17)

27. Close service compartment.

Halogen Accent Lighting

28. Changing halogen accent lamps. Detach top acrylic by applying pressure to the acrylic assembly and rotate the acrylic latches clockwise. The acrylic assembly is attached with two (2) retainers, one at the head end and one at the foot end of the canopy. (Refer to Illustration L18)

29. After detaching the acrylic assembly, carefully lower the front down, resting the assembly on the lower base of the unit.

30. Remove front five (5) tanning lamps. This will expose inner service panel. Remove inner service panel. Remove inner service panel by removing screw (A) from the inside of the head and footend of the unit.

31. Loosen screws (B) from inner panel. Pull red accent from the groove and fold up. Remove screws (B) at this time. (Refer to Illustration L19)

32. To remove halogen accent lamp (B) pull lamp and disengage from lampholder. (Refer to Illustration L20)

33. To install halogen lamp align pins in lamp with slots in lampholder and push lamp into place.

34. Repeat Steps 25 thru 31 in reverse order to reassemble.

Illustration L16

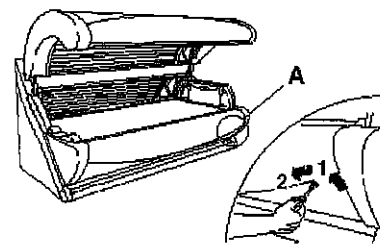

Illustration L17

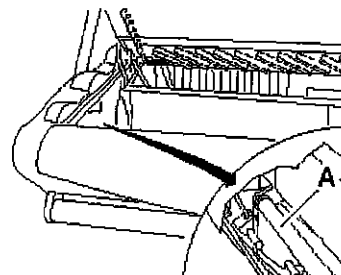

Illustration L18

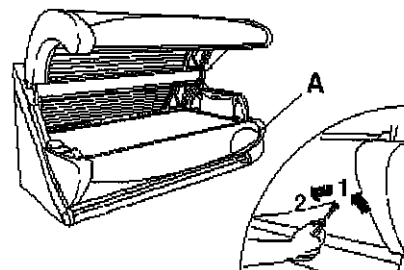

Illustration L19

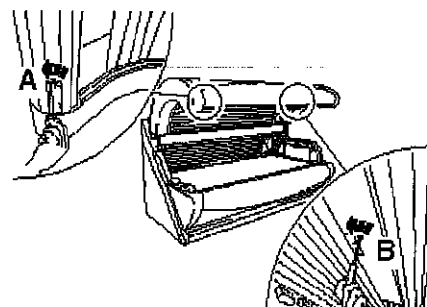
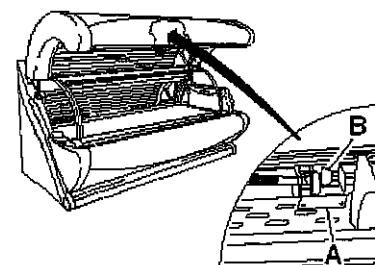

Illustration L20



Exposure Time and Frequencies

Melanin - The brownish pigment produced by special cells in the base layer of your skin determines the individual's tan. As the skin is exposed to the ultraviolet light, the melanin is activated and combines with protein cells that rise to the skin's surface, thus producing a tan.

The amount of melanin in your body determines how quickly and dark you tan. The more melanin produced and exposure time an individual has, the faster and deeper the individual will tan.

NOTE

The tan produced by the tanning unit is a deep, rich "COSMETIC" tan. However, regardless of how dark an individual may tan on this system, it will not provide adequate protection against overexposure to natural sunlight or UVB tanning systems.

SKIN TYPE II - This is the individual that usually burns easily and severely, tans minimally or lightly and peels.

SKIN TYPE IV - This individual burns minimally, tans easily and above average with each exposure.

SKIN TYPE III - Often referred to as "AVERAGE" complexion, burns moderately and tans about average.

SKIN TYPE V - This individual's system rarely burns, tans easily and substantially.

Recommended Exposure Schedule					
SKIN TYPE	WEEK 1 1 ST-3RD TREATMENTS	WEEK 2 4TH-6TH TREATMENTS	WEEK 3 7TH-10TH TREATMENTS	WEEK 4 11TH-15TH TREATMENTS	WEEKLY SUBSEQUENT TREATMENTS
II - FAIR	2 MIN.	5 MIN.	7 MIN.	10 MIN.	12 MIN.
III - AVERAGE	2 MIN.	5 MIN.	7 MIN.	10 MIN.	12 MIN.
IV - BROWN	2 MIN.	7 MIN.	10 MIN.	12 MIN.	12 MIN.
V - DARK BROWN	2 MIN.	7 MIN.	10 MIN.	12 MIN.	12 MIN.

MAXIMUM EXPOSURE TIME IS 12 MINUTES.

No two individual skin tones are the same. A tan to one person may be different to another and treatment length may vary.

NOTE: Adequate ventilation of the room or booth housing the tanning unit is required for proper and comfortable operation. Your tanning unit will perform best at the ambient temperature of 75° to 90° F. Equally important many facial makeups have oil bases and should be removed prior to a session.

It is recommended that, following a tanning session, a skin moisturizer be applied. This promotes a smoother, more even looking tan. It is recommended you do not use tanning creams or lotions intended for outdoors use.

Disassembly Instructions

Tools Required for Assembly

- 4 MM Allen Wrench
- 6 MM Allen Wrench
- 8 MM Allen Wrench
- Ergoline Service Key
- 10 MM Combination Wrench
- Phillips Screwdriver
- 2 Assembly Rails
- 1 Upper Canopy Support

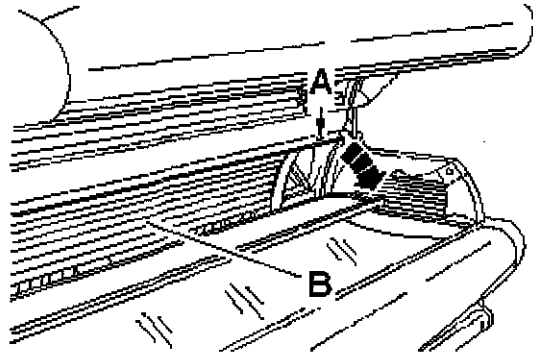

Illustration A1

Disassembly

1. **Illustration A1** Detach side panel acrylic from profile retaining frame by removing acrylic attaching screws A with Ergoline Service Key. Fold down side acrylic panel C.

2. Remove attaching screw from the starter cover and hinge down.

3. To remove lamps B turn 1/4 turn and slide lamp from lampholder. Remove all 5 lamps.

4. **Illustration A2** Unlock the bottom unit with the provided Ergoline service key. Insert the key and turn lock at the head end of the unit and turn 1/4 turn clockwise two times.

5. Raise the lower section to the full upright position to allow access to the inner unit.

6. **Illustration A3** To remove filter mat A from the front of the base unit. Remove the left hand clip on grid B and slide right hand clip on grid to the left of the unit and remove.

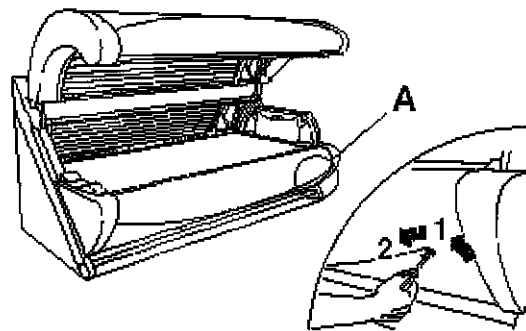

Illustration A2

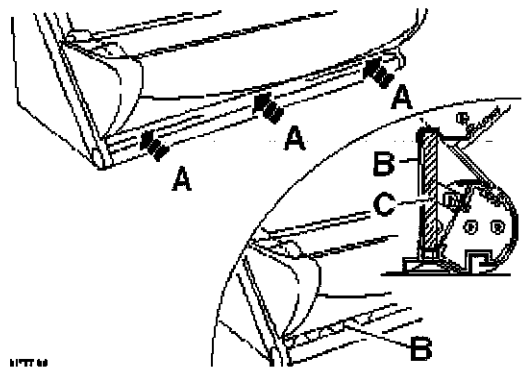

Illustration A3

Disassembly Instructions

7. **Illustration A6** Locate Ergoline System Control Unit at the left end of the lower service compartment and remove cover A.

8. **Illustration A6** Remove retainer clip from control wire B. Disconnect plug X 10 and feed control cable through cable guard.

9. Disconnect plug X9, contacts 1 and 2 (sensor lead) from circuit board and feed cable through cable guard.

10. Reattach control unit concealment cover.

11. Remove the two 6 mm attachment screws and hinge control unit assembly down. This will expose the main power connector to the base and canopy assemblies.

12. **Illustration A7** Disconnect the power connectors 1.7, 1.10, 1.12 from the receptacles and remove the cable ties.

13. Hinge control assembly back into place and attach to the rear panel with two 6 mm screws.

14. Close service access compartment.

15. Unlock bottom acrylic with the Ergoline Service key. Insert key in lock and turn clockwise 1/4 turn.

16. Raise acrylic panel assembly until locked. The panel should lock in an upright position.

17. **Illustration A8** Supporting acrylic assembly. Detach support retainers at the head of the acrylic assembly by removing the two 6 mm philips screws. Repeat procedure for foot end assembly.

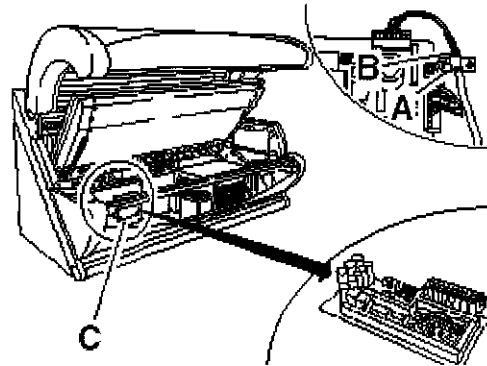

Illustration A6

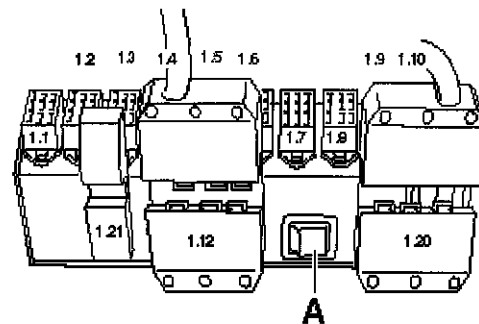

Illustration A7

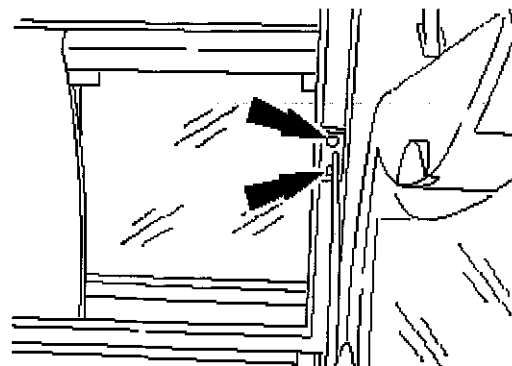

Illustration A8

Disassembly Instructions

18. Close base acrylic assembly.

19. Open service compartment with the service key. Insert key in the lock and turn clockwise 1/4 turn and raise complete base assembly to it full upright position.

20. **Illustration A9** Remove detent cable B from service compartment latch assembly from lock F. Remove cotter pin C and washer G and disengage cable hook E from lock F. Remove KL washer D and remove control cable.

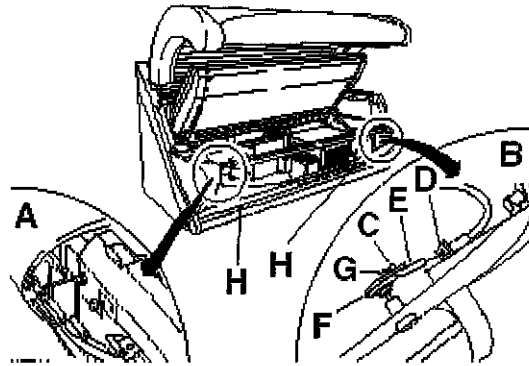

Illustration A9

21. Remove the two 8 mm socket head cap screws A from the longitudinal member and lift out.

22. **Illustration A10** Remove the eight self tapping screws A that attach the lower front accent panel. Carefully lift panel up and out of the lower section.

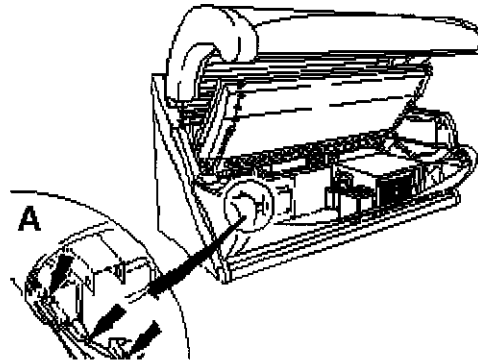

Illustration A10

23. **Illustration A11** Detach coupler of left end gas support spring from ball stud. Lift base assembly to full upright position. Insert flat blade screwdriver into slot in coupler and pry coupler retaining ring back slightly. Apply outward force to spring to disengage from ball stud.

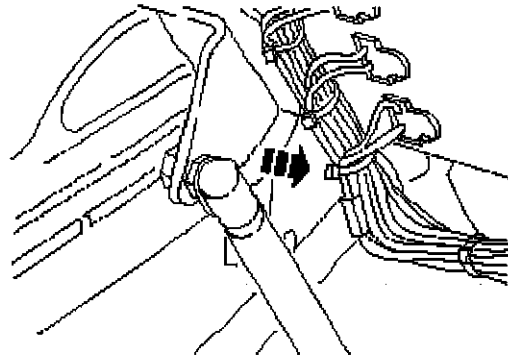

Illustration A11

24. Repeat procedure 25 for the right end gas support spring.

25. Place the supporting springs to one side.

26. Disconnect all wiring connections (1.1, 1.2, 1.3, 1.21, 1.30) to the base assembly for removal of base in step

27. **Illustration A12** Locate and remove the two 8 mm base pivot locking screws A.

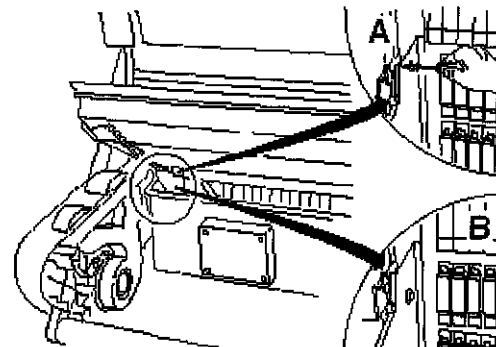

Illustration A12

Disassembly Instructions

28. **Illustration A13** Locate and insert the two assembly rails. The rail must fit securely into the slot A in the rear of unit under the base assembly rollers. Secure the each rail with a #8 self tapping screw.

29. Base assembly weighs approximately 200 pounds, and will require at least one person at each end to remove.

30. **Illustration A14** Locate release lever A at the rear or base assembly and apply downward pressure. You should feel the latch disengage. Both latches must be disengaged prior to moving base assembly to allow removal.

31. Tilt base assembly to approximately a 30 angle and pull forward. Slide base assembly evenly to avoid binding.

32. Disconnect plug from control board and ballast trays.

33. Remove both canopy harness assemblies from the routing clips and lift out. Place ends of harnesses in the service compartment.

34. **Illustration A15** Remove rear pivot accent by removing the six 5 mm machine screws A along the front of panel with a philips screwdriver.

35. **Illustration A15** Apply upward pressure to the front rail of canopy. Raise canopy high enough to allow adequate clearance for removal. Slide accent panel toward the front of unit and out of rear groove. Pivot accent panel down.

36. Pull canopy harness cable through the accent panel and place harnesses in service compartment:

37. Apply upward pressure to the front rail of canopy. Raise canopy high enough to allow adequate clearance and remove pivot accent panel.

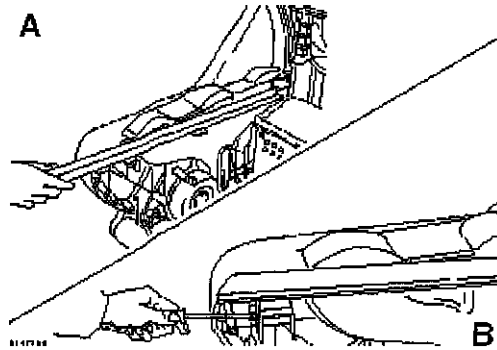

Illustration A13

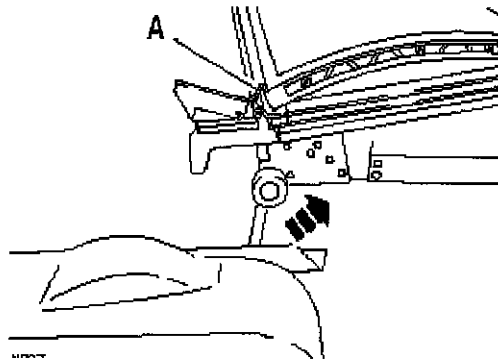

Illustration A14

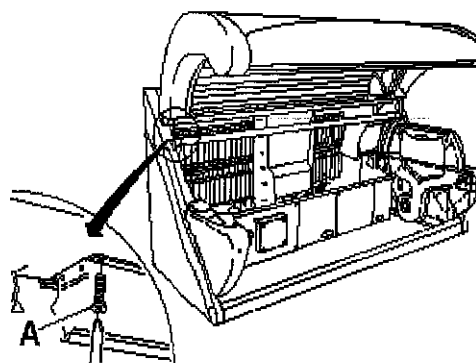

Illustration A15

Disassembly Instructions

38. **Illustration A16** Remove canopy supports B. To remove the support raise top canopy to its highest possible open height and turn canopy support rod clockwise to unthread the support from unit and remove from base.

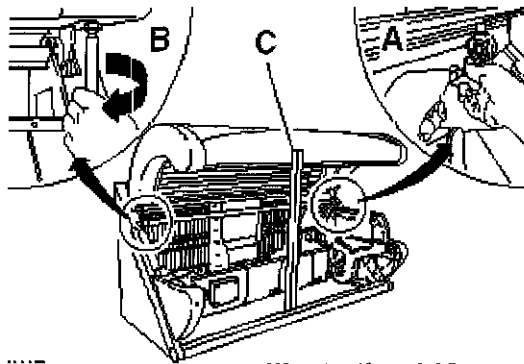

Illustration A16

39. **Illustration A16** Open top canopy to its full upright position and install the upper canopy support. Support must be positioned behind the front base cross member tube. It is also recommended that the top canopy be supported by a second person to prevent slippage of the canopy support which will result in personal injury.

40. **Illustration A16** Detach top unit from base assembly by removing the three 6mm socket head cap screws from the left and right pivot bearing A.

41. Lift canopy front from each end and remove canopy support, slide canopy forward to remove. Due to the weight of the canopy, it is recommended that this task be performed by at least four adults.

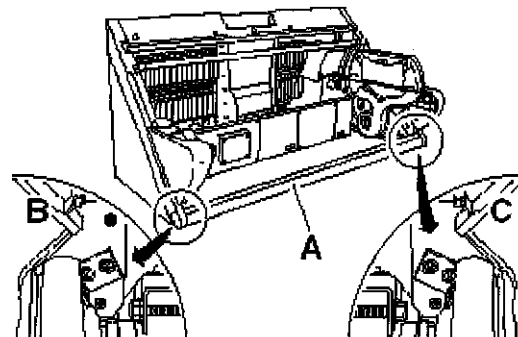

Illustration A17

42. **Illustration A17** Remove front base cross member tube A. Detach tube by removing the four self tapping philips screws B.

43. **Illustration A18** Remove profile retaining frame C from base leg sections by removing four self tapping philips screws B.

44. **Illustration A19** To detach the left base leg section remove self tapping philips screws A and B located under top of rear panel assembly.

45. Repeat procedure for right base leg section.

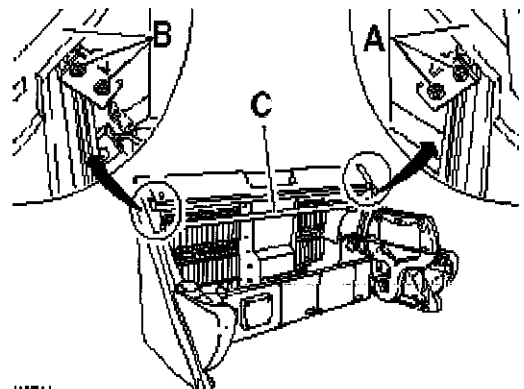

Illustration A18

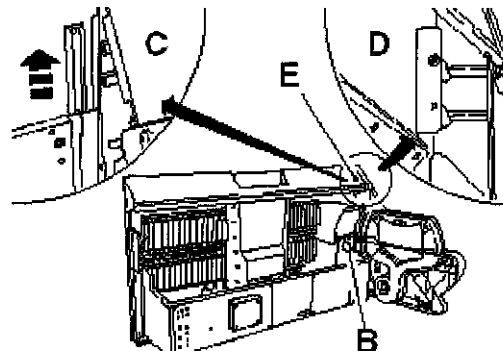
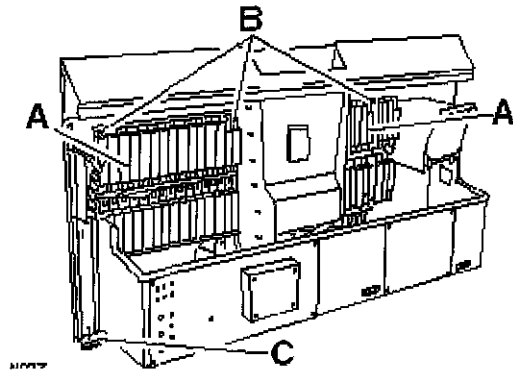

Illustration A19

Disassembly Instructions

46. **Illustration A20** It is not required but advised, due to the weight of the rear panel assembly, to remove the ballast trays A prior to transporting the rear assembly into the tanning room. Prior to removing ballast trays all electrical connections must be disconnected. Detach ballast trays A from rear panel by removing the 8mm philips screws B and lift out of place.



47. **Illustration A20** Detach the rear panel assembly by removing the self tapping screws from the lower cross member C.

Illustration A20

Assembly Instructions

1. **Illustration A20** Install Rear panel assembly in tanning room. Locate panel assembly in center of room allowing sufficient access to rear of panel for connection to electrical service.

2. **Illustration A20** Attach the ballast trays A to the rear panel assembly with 8 mm philips screws if removed prior to installation.

3. **Illustration A21** Install left base leg section to rear panel assembly. Align the slot in the left leg section with tabs in the rear panel and slide leg section into place. Slide rear profile retainer C down to secure leg section.

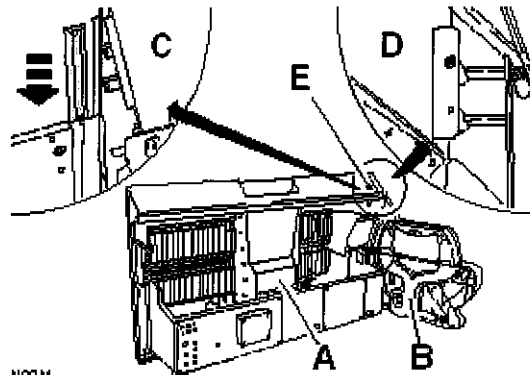

Illustration A21

4. **Illustration A21** Complete leg section attachment by securing to the rear panel with two self tapping philips screws A and B located under the top of the rear panel assembly.

5. Repeat Steps 3 and 4 for right base leg section.

6. **Illustration A22** Attach profile retaining frame C to base with four self tapping philips screws B.

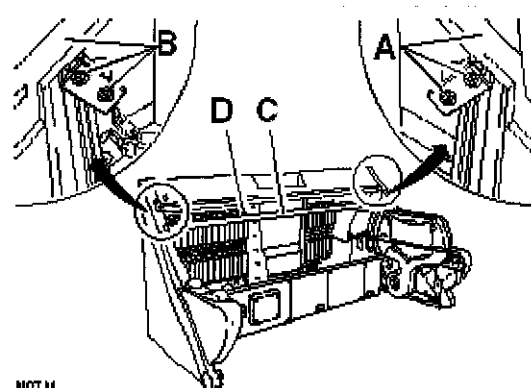

Illustration A22

Assembly Instructions

7. **Illustration A23** Attach front cross member tube A to the base assembly with four philips screws B.

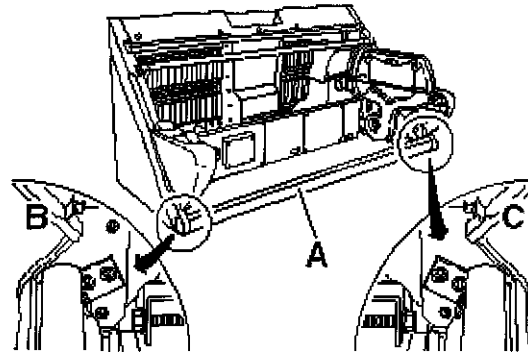

Illustration A23

8. **Illustration A24** To install the top canopy, lift canopy into place from both ends. Slide rear pivot attaching brackets into place aligning with pivot bearing and attach with three 6 mm socket head cap screws at each end of top canopy.

Note: Canopy must be supported in the front by the canopy support to allow installation of the support rod. Failure to support the canopy will cause canopy to fall and result in damage to the unit and possible personal injury.

9. **Illustration A25** With canopy supported in it full upright position by the canopy support install the canopy support rods. Install support rods by inserting rod into tubing in leg base assembly. Attach support rod to canopy by threading the rod counter clockwise onto rod coupler.

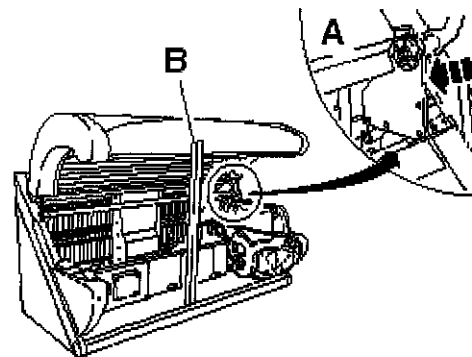

Illustration A24

10. **Illustration A26** Apply upward pressure to the front rail of the canopy. Raise canopy high enough to allow adequate clearance and install pivot accent panel.

11. **Illustration A26** Feed canopy harness cables through accent panel and connect harness to the required plugs. Take note to match plug designation number to corresponding number on receptacle.

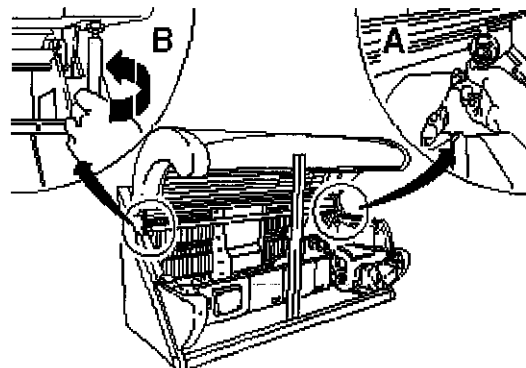

Illustration A25

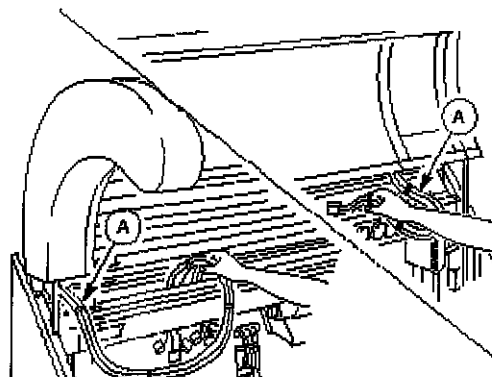

Illustration A26

Assembly Instructions

12. **Illustration A27** Slide flange located at the rear of the accent panel into provided groove in back rail of canopy. Attach accent panel to canopy with six 5mm philips screws.

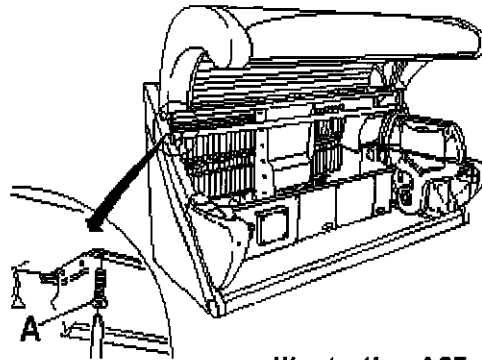

Illustration A27

13. **Illustration A28** Check the lateral alignment of the top canopy. If the canopy needs adjusting, adjust the gap between the canopy and base with the canopy support rods. Raise top canopy and turn support rod clockwise to raise and counter clockwise to lower.

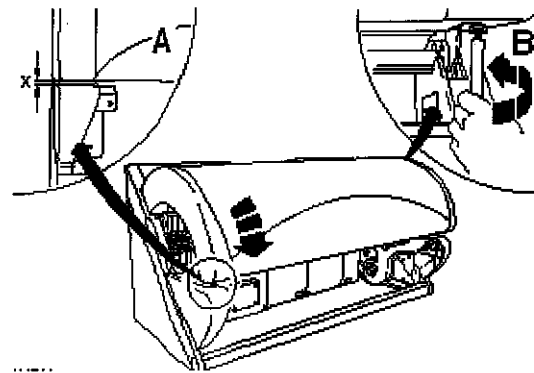

Illustration A28

14. **Illustration A29** Install the two assembly rails. Position rails to the rear of slot A allowing sufficient clearance for the base assembly latches to fit into place.

Note: Base assembly weighs approximately 200 pounds and will require at least one person at each end of assembly for lifting.

15. **Illustration A30** Install base assembly. To install base assembly tilt assembly to approximately a 30 degree angle and place the rollers on the assembly rails and roll assembly evenly to the back of rail to prevent binding. Base assembly should latch into the required position.

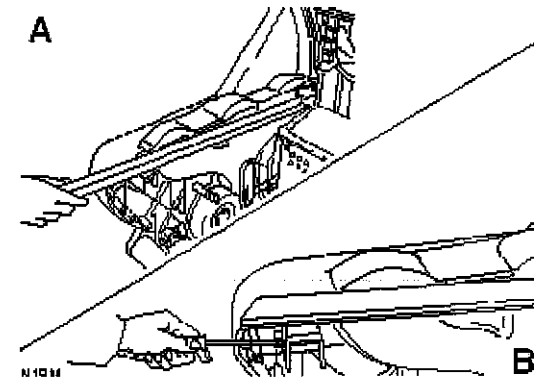

Illustration A29

16. Check to insure base assembly will not pull forward and remove assembly rails at this time.

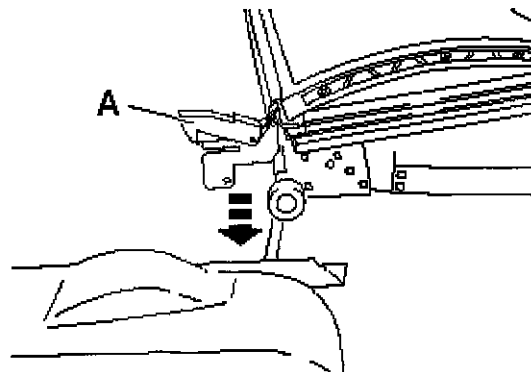

Illustration A30

Assembly Instructions

17. **Illustration A32** Install the two 8 mm socket head cap screws A into pivot hole B and tighten securely.

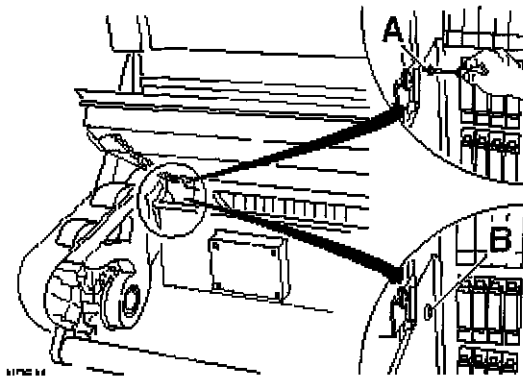

Illustration A32

18. **Illustration A33** Install base unit support springs. Lift base assembly to full upright position and place the end of the gas support spring onto the end of the ball stud coupler and apply pressure allowing the spring to snap over coupler.

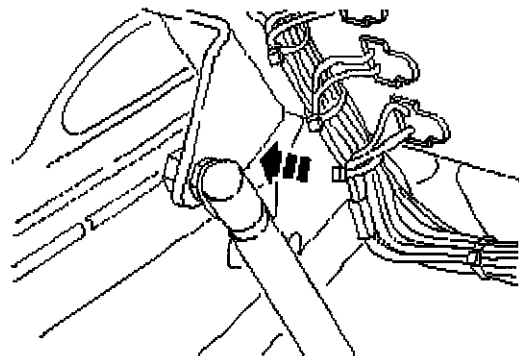

Illustration A33

19. **Illustration A33** Connect wiring harness connections (1.1, 1.2, 1.3, 1.21, 1.30) from base assembly to electronics. Wiring connections are keyed and which should not allow improper hookup. It is also important the connector be fully seated into the receptacle to prevent arcing and potential failure.

20. **Illustration A34** Install lower accent panel. Lift panel into service compartment and locate panel in the required position and secure panel with eight self tapping screws A.

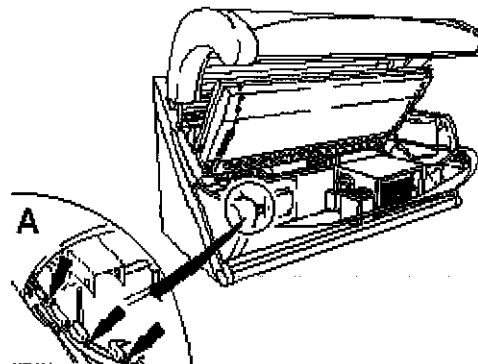

Illustration A34

21. **Illustration A35** Place longitudinal cross member into place over the mounting brackets attached to the side leg panels and secure with two 8 mm socket head cap screws A.

22. **Illustration A35** To assemble lock mechanism, place KL washer D over cable hook E and engage cable hook E onto linkage F. Place washer G over cable hook E and secure cable with cotter pin C.

23. Close service compartment.

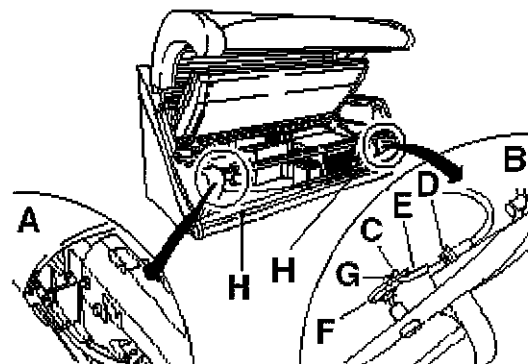

Illustration A35

Assembly Instructions

24. **Illustration A36** Attach acrylic supports. Raise acrylic panel assembly and attach support retainer to the acrylic assembly with two 6 mm philips self tapping screws. Repeat procedure for opposing end.

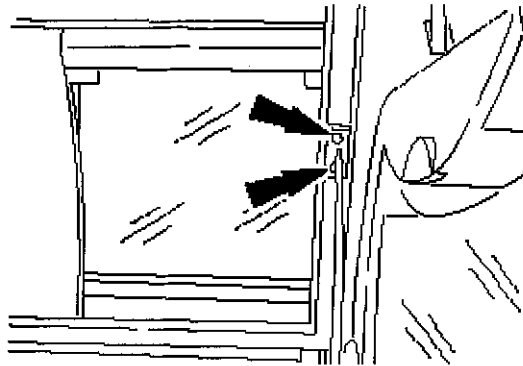

Illustration A36

25. **Illustration A37** Open service access compartment and locate Ergoline System Control Unit at the left end of compartment. Remove cover A. Connect plugs X 10 control cable and plug X 9 contacts 1 and 2 sensor lead to control board B. Reattach cover A.

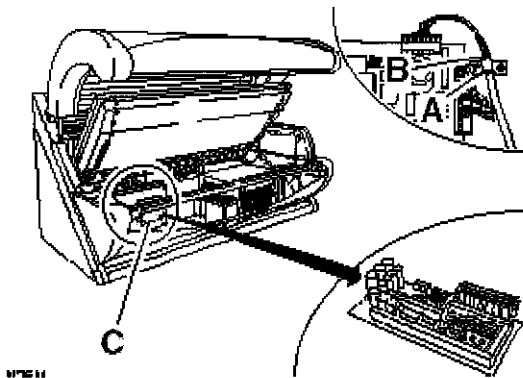

Illustration A37

26. **Illustration A38** Remove the two 6 mm attachment screws and hinge control unit assembly down. This will expose the main power connectors to the base and canopy assemblies. Connect main power connectors 1.7, 1.10, 1.12. Check all connections to insure proper seating.

27. **Illustration A39** To attach front accent cover place cover into required location noting that each side is aligned properly with base side panels. It should also be noted that the top edge of the front lower accent panel is under the cover. Secure cover with two 6mm self tapping screws.

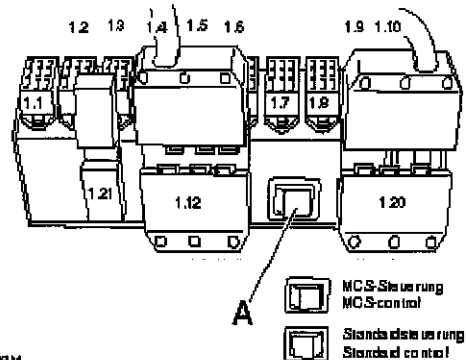

Illustration A38

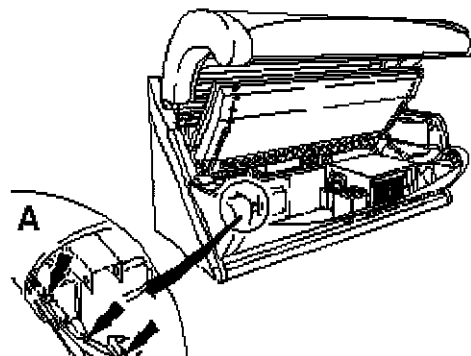

Illustration A39

Assembly Instructions

28. **Illustration A40** Install filter mat B behind front cross member. Slide both retainer clip over filter B. Install filter A into place and slide one clip over filter a to secure.

29. Close service compartment.

30. **Illustration A41** Install lamps A inside lamp panel. Insert lamp in lamp holder and turn 1/4 turn. To avoid potential damage, it is important not to force the lamp into place. The lamps if seated in lampholder properly will rotate easily.

31. Rotate starter cover up over head end of lamps concealing the starters and attach with a socket head screw. Tighten screw with the Ergoline Service Key.

32. Rotate side panel acrylic into place and attach with the acrylic screws. Secure acrylic assembly with the Ergoline Service Key.

33. Contact Licensed Electrician for unit service connection. This Ergoline Model 600 must be connected to a single phase electrical service of between 220 Volts to 240 Volts. If your salon's electrical service does not meet these requirements refer to pages 20 and 21 of this manual.

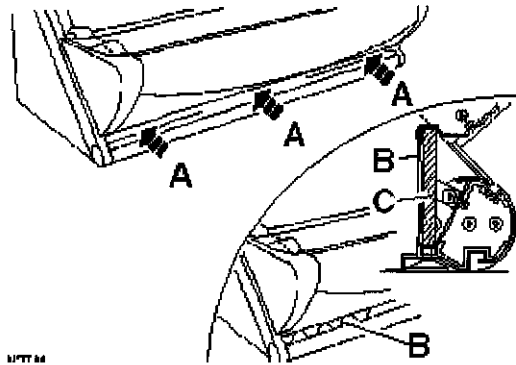

Illustration A40

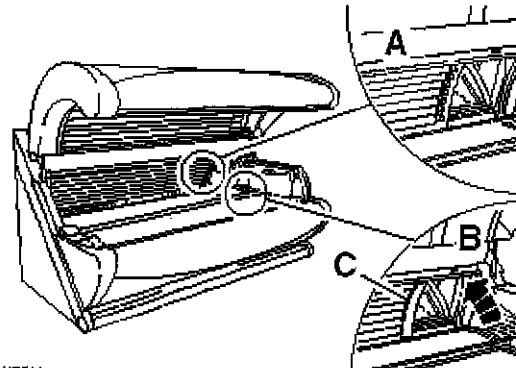
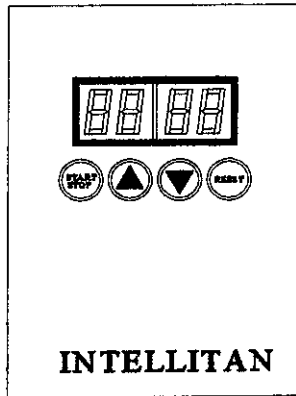

Illustration A41

Intellitan by Sun Ergoline Operating Instructions



To Set Time

STEP 1: Press **s** button to reach desired setting in minutes.

STEP 2: Press **Start/Stop** to begin operation. The session is counted down in minutes and seconds.

NOTE: If a session delay is preprogrammed (P04), the display will begin to flash the session time. The display will continue to flash the session time for the duration of the session delay according to the programming or until **Start/Stop** the button is pressed. If the **Start/Stop** button is pressed before the session delay expires, the display will stop flashing and the session time will begin to count down. At **one (1) minute**, before the start of the tanning session, an audible beep will sound (if programmed in P02). At **thirty (30) seconds**, before the start of the tanning session, another audible beep will sound. At **ten (10) seconds** the audible beep will sound and continue once each second until tanning unit lights. Once the tanning unit has started, the session delay will not repeat on subsequent restarts.

To Stop Unit

STEP 1: Press **Start/Stop** anytime during a session. This will stop the countdown and hold time. To restart the unit simply press Start/Stop.

To Clear Time

STEP 1: Press **Reset**, the timer clears to read 00:00.

NOTE: If the unit is counting down, the **Start/Stop** button must be pressed before resetting.

To Change Parameters

To enter the System's data bank, monitor operations and verify the vital functions concerning your unit, use the following step-by-step instructions. **Note:** Each timer manufactured after 1995 displays the current software version on power up. These instructions are for level 23 and above of the Intellitran Plus timer.

Enter Password Clearance

1. Press (at the same time) then release **s** and **t** buttons; the display will change from 00:00 to 0000. If you cannot get the display to change to 0000, assure that you have disconnected the network cable(s) from the timer. If power to the tanning unit is not cycled on/off after disconnecting the network cable, you must wait for thirty seconds for the timer to award access to the above mentioned buttons.
2. Press the **Reset** button once so that 0000 begin to flash.
3. Use the **s** button to enter the appropriate password to perform the desired function. Password 0010 (ten) must be entered to view parameters, and 0102 (one hundred and two) to edit parameters. After entering the password press the **Reset** button. The display will stop flashing and 0001(level one) or 0002 (level two) will appear in the display.
4. Press the **Start/Stop** button to reach the desired parameter. If you go past a parameter press the **st** button to exit parameter mode and restart from step 1. Each time the **Start/Stop** is pressed the timer will display PXX (XX represents numbers) representing the parameter reached and then the display will change showing the value of the parameter.
5. If you are using the second level password, press the **Reset** button to edit the parameter (once the **Reset** button is pressed the display will begin to flash). Use either the **tor** or **s** button to set the appropriate value for the parameter, then press **to** to exit the parameter.
6. Press the **Start/Stop** to advance to the next parameter. You may **st** press buttons simultaneously to exit the edit parameter mode.

P02 Parameter 2 is the chime mechanism that provides an audible 'beep' sound when the keys are depressed and to indicate the various operations occurring. The audible beep can be turned on or turned off. The unit comes with the chime mechanism turned on to provide an audible beep.

When parameter 02 is shown, the display will read 0001. To maintain the chime mechanism, press the **s** now and go to **P03**. To silence it, do the following:

To Change Parameter 2, Alarm On/Off

Press **Reset** once then release it. The display will begin to flash. Press **t** and hold it down, scrolling down to 0000. Now press **Reset** once again. The chime is now deactivated. To reactivate the chime, change parameter 02 back to 0001 using the same instructions provided above.

Now press **Start/Stop** to reach **parameter 4 P(05)**, the **session delay**.

P04 Parameter 4 is the session delay. The session delay allows a programmable amount of time at the beginning of a session to get ready for the tanning session. The tanning session time shown on the timer flashes during the session delay. The unit comes with no session delay preprogrammed.

To Change Parameter 4, Session Delay

When parameter 04 is shown, the display will read 0.0 for no session delay. To change the session delay, do the following:

Press **Reset** once then release it, the display will begin to flash. Now press **s** or **t** to reach the desired setting. Time is displayed from 0.0 to 10.0, with the decimal representing tenths of a minute. For Example: 2.5 equals 2 minutes, 30 seconds. After reaching the desired setting, press **Reset** once and release it. Session delay is now set. Now press **Start/Stop** to reach **Parameter 5 (P05)**, the **Station Address** function.

P05 Parameter 5 is the station address. The station address allows the tanning unit to be identified for interface with the CCS series controllers, the Intellititan Single Station Console, or the Intellititan Protocol Interface (IPI) for your computer system. The unit comes with a station address of zero (0) preprogrammed. If you have multiple units each must be uniquely addressed.

To Change Parameter 5, Station Address

When parameter 05 is shown, the display will read 0000 for station address zero. To change the station address, do the following:

Press **Reset** once and release it, the display will begin to flash. Now press **s** or **t** to reach desired address setting. Once the desired setting is reached press **Reset** once and release it. The station address is now set.

Now press **Start/Stop** to reach **Parameter 6 (P06)**, the **Lamp-Hour Accumulation on Current Lamp Bank** function.

P06 Parameter 6 is the lamp hour accumulation counter. The lamp hour accumulation counter keeps track of the number of hours on the current lamp bank. This is a resettable parameter that should be reset to 0 when the lamps are changed. When current lamp hour accumulation reaches 1000, a beep will chime each time the unit is turned on, indicating that a lamp change is necessary. Chime will not sound if it has been turned off through parameter 2. Parameter 6 is only editable at password level 1.

When parameter 06 is shown, the display will read from 0000 to 9999. To clear the lamp hour accumulator, do the following:

To Clear Parameter 6, Lamp Hour Accumulation

Press **Reset** once and release, the display will begin to flash. Now press **⏏** and hold until 0000 is displayed. When the display reads 0000 press **Reset** once and release. Lamp hour accumulation is now cleared.

Now press **Start/Stop** once and release it to advance to **Parameter 15 (P15), clean room feature**.

P15 Parameter 15 is the clean room feature. When "on", the clean room feature will show all dashes (----) on the timer display at the end of each tanning session to show that the tanning unit needs to be cleaned. In network mode, no new time can be placed on the timer when the clean room indicator is displayed.

To reset the clean room feature from the room, indicating that the room has been cleaned, press the **Reset** button twice in rapid succession. When the clean room feature is reset, the in room timer will display 00:00. The unit comes with the clean room feature off.

To Change Parameter 15, Clean Room Feature

Press **Reset** once then release it, the display will begin to flash. Now press **⏏** once to display 0001, then press **Reset** once and release it. The Clean Room Feature is now enabled. To disable the Clean Room Feature simply change parameter 15 back to 0000.

Now press **Start/Stop** once and release it to reach **Parameter 16 (P16), The Econometer**

P16 Parameter 16 is the Econometer. The Econometer measures the electrical cost to power unit for previous session or the current session if the tanning unit is active. The cost displayed is derived from the session cost per minute entered in P17. The reading is displayed immediately. Measurement is in cents and tenths of a cent. This function is read only and can not be changed.

For Example - A reading of 10.7 would equal 10.7 cents.

Now press **Start/Stop** once and release it to reach **Parameter 17 (P17), Cost Per Session**.

P17 Parameter 17 is the session cost per minute. This figure is automatically entered into the tanning unit's data bank in accordance with the National Average of **7.5¢** per kilowatt hour. The formula used is $\text{Unit_KwH_Draw} \times \text{National_Average} / 60_{\text{minutes}} = \text{cost per minute}$. In the case of the R32B this is $3.1 \times 7.5 / 60 = 0.388$ rounded up to .4 cents per minute.

To Change Parameter 17, Cost Per Minute

Press **Reset** once then release it, the display will begin to flash. Now press **s** or **t** until the desired cost per minute is displayed. Measurement in cents and tenths of a cent. For Example. A reading of .4 would equal four tenths of one cent. Once the desired reading is displayed press **Reset** once and release it. The Cost Per Minute is now set.

Now press **Start/Stop** once and release it to reach **Parameter 18 (P18), The Session Counter**.

P18 Parameter 18 is the Session Counter. The session counter displays the total number of times a session has been started since first day of operation. The session counter counts from 0000 to 9999 then rolls over. The session counter cannot be adjusted or reset.

Now press **Start/Stop** once and release it to reach **Parameter 19 (P19), Total Hour Accumulation**.

P19 Parameter 19 is the total hour accumulator. This accumulator displays the total number hours on the unit since first day of operation. The accumulator counts from 0000 to 9999 then rolls over. The total hour accumulator cannot be adjusted or reset.

Now press **Start/Stop** once and release it to reach **Parameter 24 (P24), Continuous Countdown Mode**.

Note: Parameters 20-23 are reserved for factory use.

P24 Parameter 24 is the continuous countdown mode toggle. The default is 0 for disabled. The continuous countdown mode allows the salon owner to maintain a tighter schedule by disabling the pause function of the timer thus allowing the tanning time to continue to count down even if the lamps are turned off by pressing the start/stop key. This feature is only available with software level 16 or higher.

To Change Parameter 24, Continuous Countdown Mode

Press **Reset** once then release it, the display will begin to flash. Now press **s** until 0001 is displayed, press **Reset** once and release it. Next cycle the power to the timer and tanning unit off and back on. The Continuous Countdown Mode is now enabled. To disable this function change parameter 24 back to 0000.

Now press **Start/Stop** once and release it to reach **Parameter 25 (P25), Keylock Configuration**.

P25 Parameter 25 is the keylock configuration option. The default is 3 for 30 seconds. The keylock configuration option allows the salon owner to maintain a higher sense of security by locking out the front rail keys in several specified intervals while the timer is connected to a network. This feature is only available with software level 16 or higher. The keylock intervals are:

- 0 - Lock keys and release only when power cycled.
- 1 - Lock keys and release only when parameter is changed to an option other than 01.
- 2 - Lock keys and release only after the network cable has been removed for 2 minutes.
- 3 - Lock keys and release only after the network cable has been removed for 30 seconds.

WARNING: If you set parameter 25 to 01 (Lock until parameter changed) you will be unable to change this parameter or unlock the front rail keys without the use of a CCS-1 or other control device. The Intellitran Protocol Interface (IPI) does not edit this or any other parameter.

To Change Parameter 25, Keylock Configuration

Press **Reset** once then release it, the display will begin to flash. Now press **s** until the desired option 0,1,2,3 is displayed, press **Reset** once and release it. Next cycle the power to the timer and tanning unit off and back on. The Keylock Configuration is now saved.

Now press **Start/Stop** once and release it to reach **Parameter 26 (P26), TPI Interface Enable.**

P26 Parameter 26 is the Third Party Interface (TPI) Mode toggle. The default is 0 for disabled. The Intellitran Plus timer has a TPI jack built in to the timer itself. This jack replaces the need for a second or additional interface when using other timer systems. The TPI jack is located next to the two network jacks on the top of the tanning unit (under the hinge cover). It is the larger of the three jacks and comes with a unused modular plug in the jack. When using the Intellitran Plus timer in TPI mode the Intellitran Plus looks for control voltage (5-30v) on the outside two wires of the modular cable plugged into the TPI port. When this voltage is seen, the maximum tanning time is sent to the timer and the tanning unit is started. Any session delay should be programmed on the third party timer and the Intellitran session delay should be set to 0. The front rail keys are locked in TPI mode. This feature is only available with software level 16 or higher.

To Change Parameter 26, TPI Mode

Press **Reset** once then release it, the display will begin to flash. Now press **s** until 0001 is displayed, press **Reset** once and release it. Next cycle the power to the timer and tanning unit off and back on. The TPI Mode is now enabled. To disable this function range parameter 26 back to 0000.

Now press **Start/Stop** once and release it to reach **Parameter 27 (P27), Timer Protocol Option.**

P27 Parameter 27 is the Timer Protocol Option. The default is 0 for Intellitron Protocol. The timer protocol option allows the salon owner to change timer network protocols from the Intellitron Network to the T-Max¹ protocol for use with the Applied Digital T-Max Manager. For additional information please consult the T-Max documentation. This feature is only available with software level 16 or higher.

To Change Parameter 27, Timer Protocol Option

Press **Reset** once then release it, the display will begin to flash. Now press **S** until 0001 is displayed, press **Reset** once and release it. Next cycle the power to the timer and tanning unit off and back on. The T-Max Protocol is now on. To turn off this function change parameter 27 back to 0000 using the parameter edit instructions in the T-Max documentation. You can not use a CCS-1 or IPI with a timer using T-Max Protocol.

Now press **Start/Stop** once and release it to reach **Parameter 28 (P28), Total Operating Cost.**

P28 Parameter 28 is the Total Operating Cost Accumulator. This parameter tracks total operating costs of the tanning unit based upon parameter 17, session cost per minute. This parameter is displayed in dollars and tenths and rolls over at \$999.9. The Total Operating Cost Accumulator can be reset to 0 at anytime in order to track or determine daily, weekly, monthly, quarterly, or annual operating costs.

To Change Parameter 28, Total Operating Cost

Press **Reset** once then release it, the display will begin to flash. Now press **S** until 0000 is displayed, press **Reset** once and release it. The Total Operating Cost is now reset to 0 and will begin accumulating at the next session.

Now press **Start/Stop** once and release to reach parameter **Parameter 30 (P30), Facial Control.**

¹

T-Max is a registered trademark of Salon Systems, Inc./Applied Digital, Inc. Branson, MO.

General Troubleshooting Guide

The following troubleshooting information is divided into two sections. Section A contains items in which the owner may check without the aid of a service person. Section B contains items which must be performed by **QUALIFIED SERVICE PERSONNEL ONLY**. If you have any questions other than the ones listed in your troubleshooting guide, contact your dealer or distributor.

(NOTE: All tanning units are not the same, therefore some of the causes may not apply to your unit.)

General Troubleshooting (Section A)

1. Tanning unit does not operate.

CAUSE

1. No power to unit.
2. Timer is not activated.

SOLUTION

1. Check circuit breaker servicing bed.
2. Press up button, then start button.

(Note: If there is power to the unit but the display on the timer is not lighting, you may need to replace the power board and/or the C.P.C. board. Contact Sun Ergoline or your local representative for information.)

2. Lamps will not light or lamps flicker.

CAUSE

1. Lamp not seated properly in lampholder.
2. Faulty Lamp.

SOLUTION

1. Remove lamp, inspect contact on lamp, and reinstall lamp securely into lampholder.
2. Replace lamp. (Refer to Instruction Manual for correct lamp.)

3. Top unit does not hold its position.

CAUSE

1. Springs need to be adjusted.

SOLUTION

1. Refer to spring adjusting in your Operation and Instruction Manual.

General Troubleshooting (Section B)

All services in the following section are to be completed by a Qualified Service Technician. This section is to aid in isolating and correcting and problems which may occur and is not intended for the use by the owner. Refer to the assembly instructions included with each unit for reference in disassembling and wiring the tanning unit. Disconnect all power to the unit before servicing. Use only factory authorize components for replacement parts.

1. Tanning unit does not operate.

CAUSE

1. Incorrect connection of incoming power.
2. Faulty timer.
3. Faulty relay in bed.
4. Poor wiring connections.

SOLUTION

1. Check electrical connection on wiring diagram and correct as necessary.
2. Replace.
3. Replace.
4. Check wiring circuit against appropriate wiring diagram and correct as required.

2. Lamps will not light.

CAUSE

1. Poor wiring crimp at lampholder.
2. Faulty or damaged lampholder.
3. Incoming power to unit incorrect.
4. Faulty ballast.
5. Loose power wire to ballast.

SOLUTION

1. Check for loose wire and repair.
2. Replace.
3. Check incoming voltage and correct to requirements.
4. Locate and replace.
5. Locate loose wire and repair.

SUN ERGOLINE

Limited Warranty

Sun Ergoline warrants its products to be free from defects in materials and workmanship under intended normal use as described in the unit's Operation and Instruction Manual, for a period of three (3) year from date of sale.

This Limited Warranty applies only to the original purchaser of the equipment through Sun Ergoline or its authorized dealer or distributor, and is not transferable.

Sun Ergoline obligations under this warranty are limited to repair or replacement of any defective part without charge for that part to the original purchaser, with the following exceptions:

- A. Fluorescent lamps are warranted against defects for a period of thirty (30) days from date of sale.
- B. Only parts obtained through Sun Ergoline, its authorized dealers or distributors may be used. Transportation costs for parts shipped to the consumer and the return of defective parts to Sun Ergoline are not included.
- C. Labor will be furnished without charge for ninety (90) days from date of purchase only. All labor and related charges must be authorized by Sun Ergoline prior to start of repairs, and must coincide with Sun Ergoline established rates and time allotment policy.
- D. Acrylic: Refer to Manufacturer's Acrylic Warranty Policy.

It is imperative that the original customer completes and returns the enclosed warranty card within 10 days after purchase to insure valid registration and coverage for potential claims.

If the warranty card is not registered, proof of purchase from Sun Ergoline or its authorized dealer or distributor will be required prior to any consideration on warranty claims. This could result in service delays.

This warranty is extended to the individual or legal entity, whose name appears on the warranty registration card filed with Sun Ergoline or whose name appears on the original sale document and may not be transferred to any other individual or legal entity.

This warranty does not apply to any failure of the product, or any parts of the product due to alterations, modifications, misuse, abuse, accident, improper maintenance, improper installation, acts of God or if the serial number on the product has been removed, altered or defaced. Adequate packaging must be used for returned goods to prevent freight damage.

THERE ARE NO WARRANTIES WHICH EXTEND BEYOND THE DESCRIPTION ON THE FACE HEREOF. THERE IS NO EXPRESS OR IMPLIED WARRANTY OF FITNESS OR MERCHANTABILITY.

THE REMEDIES PROVIDED IN THIS LIMITED WARRANTY ARE THE EXCLUSIVE REMEDIES PROVIDED TO THE PURCHASER BY SUN ERGOLINE AND ARE PROVIDED IN SUBSTITUTION OF ALL OTHER REMEDIES. CONSEQUENTIAL AND INCIDENTAL DAMAGES ARE EXCLUDED.

No person, firm or corporation is authorized to obligate Sun Ergoline for any liability in connection with the sale or use of these goods.

Limited Acrylic Warranty

Sun Ergoline warrants its acrylic sheets to be free from defects in material and workmanship, under intended normal use, for a period of one (1) year from date of sale of the tanning bed. Due to the tanning lotions, cosmetics, disinfectant and improper cleaners used on tanning surfaces that cannot be controlled by Sun Ergoline, after the first ninety (90) days of warranty period. Acrylic will be subject to a prorated cost to the consumer on breakage.

Sun Ergoline obligations do not include transportation charges on replacement acrylic.

Sun Ergoline assumes no liability for the cost of removing defective sheets or installing replacement sheets, nor for damage to persons or property.

To make a claim, contact an authorized dealer or distributor of Sun Ergoline or Sun Ergoline Service Department with the model number, the serial number, and the date of purchase of the bed in which the acrylic will be used.

THERE ARE NO WARRANTIES WHICH EXTEND BEYOND THE DESCRIPTION ON THE FACE HEREOF. THERE IS NO EXPRESS OR IMPLIED WARRANTY OF FITNESS OR MERCHANTABILITY.

THE REMEDIES PROVIDED IN THIS LIMITED WARRANTY ARE THE EXCLUSIVE REMEDIES PROVIDED TO THE PURCHASER BY SUN ERGOLINE AND ARE PROVIDED IN SUBSTITUTION OF ALL OTHER REMEDIES - CONSEQUENTIAL AND INCIDENTAL DAMAGES ARE EXCLUDED.

Sun Ergoline
P.O. Box 2026
Jonesboro, Arkansas 72402
1-800-445-0624
870-935-1130 (in Arkansas)

Warranty Claims

Policy & Procedures

1. When to file a Warranty Claim:

In the event that your tanning system is not functioning properly under intended normal use as described in the unit's Operation and Instruction Manual, you may then have established cause to file a Warranty Claim.

NOTE: Both the tanning system and legal registered owner must meet the criteria established under Sun Ergoline Limited Warranty as described in this manual before any Warranty Claim will be considered.

2. Where to call to place a Warranty Claim:

Sun Ergoline is supported nationwide by an extensive dealer/distributor network through whom the majority of our units are sold. These dealers/distributors are required by contract to stock sufficient parts to meet the various warranty and nonwarranty needs of their customers.

Therefore, in order for you to properly file a Warranty Claim, you must locate the name and phone number of the dealer/distributor through whom you purchased your unit. Normally this information can be easily located either on your paid invoice or other proof of purchase documentation that you received when taking delivery of the unit.

Next, notify the dealer/distributor of the serial number, model number and date unit was purchased. This will initiate the Warranty Claim process.

Upon determination of the problem, your dealer/distributor can then supply you with the part(s) and proper instructions to return your unit to working order.

Each dealer/distributor has their own internal procedure for handling Warranty Claims and credits.

NOTE: Sun Ergoline, the manufacturer, does not involve itself in the direct handling of a Warranty Claim except where mitigating circumstances apply and where required by law.

Parts Warranty Claim/Credit Review

1. Customer calls Sun Ergoline and notifies the Service Department of problem.
2. Sun Ergoline Service Department determines course of action.
3. Sun Ergoline ships part and R.A.I. to customer freight collect and bills customer on net30 basis for part only.
4. Customer, within 15 days of receiving new part, returns defective part to Sun Ergoline along with R.A.I.
5. Upon receipt of defective part and R.A.I., Sun Ergoline issues customer a credit invoice which offsets original bill. Customer's account is returned to zero balance concerning this claim.

NOTE: If part returned to Sun Ergoline proves to be operational and not defective, or if product code numbers on part do not correspond with individual unit date on file with Sun Ergoline, then a 30% restocking fee will be charged in addition to the retail purchase price of part.

Acknowledgment of the Agreement is not required for acceptance of the foregoing stipulations.

LABOR WARRANTY CLAIM/CREDIT PROCEDURES

Sun Ergoline furnishes labor without charge for a period of 90 days from date of purchase. All labor and related charges must be authorized by Sun Ergoline **prior** to start or repairs, and must coincide with Sun Ergoline established rates and time allotment policy.

Please contact our Service Department for authorization and billing procedures.

Limited Lifetime Warranty

Sun Ergoline warrants specific individual components of the Genesis tanning systems against defects in materials and workmanship for the life of the product. Coverage is limited to units purchased after November 1, 1994.

This warranty is restricted by the following components only:

- Steel Back Panels
- Structural Steel Frame Components
- Exterior Steel Body

NOTE: Components are warranted on an individual basis and not as they may effect the complete product.

Warranty coverage does not include cosmetic abnormalities such as scratches, nicks, dents, oxidation of paint or other cosmetic changes that do not interfere with the designed function of the unit.

This warranty does not include failure of the product due to alteration, modifications, misuse, abuse, improper maintenance, improper installation or repair.

This warranty is not transferable and is only applicable to the original purchaser named on a completed and registered warranty record at Sun Ergoline headquarters.

Sun Ergoline obligations do not include transportation charged on the shipping of new components to the customer or on the return of defective components of the manufacturer. All freight charges must be paid by the customer.

THERE ARE NO WARRANTIES WHICH EXTEND BEYOND THE DESCRIPTION ON THE FACE HEREOF. THERE IS NO EXPRESS OR IMPLIED WARRANTY OF FITNESS OR MERCHANTABILITY.

THE REMEDIES PROVIDED IN THIS LIMITED WARRANTY ARE THE EXCLUSIVE REMEDIES PROVIDED TO THE PURCHASER BY SUN ERGOLINE AND ARE PROVIDED IN SUBSTITUTION OF ALL OTHER REMEDIES - CONSEQUENTIAL AND INCIDENTAL DAMAGES ARE EXCLUDED.
